

# magnoplast

## INSTRUCTION



## MAGNACOR

## UNDERGROUND SEWERAGE SYSTEM

*Among the rich offer of sewage systems present in the market, the products of MAGNACOR have unique characteristics:*

- Resistance to waste water within the range of pH 2÷12; also to salt and means for winter road maintenance;*
- Resistance to waste water up to a temperature of 95°C with a continuous flow;*
- Low weight with easy installation and low transport costs.*



## Table of content:

<i>INTRODUCTION</i>	4
<i>ADVANTAGES OF THE SYSTEM</i>	5
<i>USE</i>	6
<i>DESIGN</i>	7
<i>STORAGE</i>	10
<i>ASSEMBLY</i>	11
<i>PIPE LAYING CONDITIONS</i>	12
<i>CERTIFICATES</i>	14
<i>LIST OF VALID STANDARDS</i>	15
<i>PRODUCT RANGE</i>	16



## INTRODUCTION

**MAGNACOR is a system of pipes and fittings made of polypropylene** manufactured using the method of extrusion, injection and extrusion welding, meeting the requirements of standard **PN-EN 13476-3+A1:2009**. Components of the system are characterised by a double-wall structure, which means they maintain high ring stiffness of 8 kN/m<sup>2</sup>. Magnacor system is offering lower weight in comparison not only to stoneware or concrete sewerage system components, but also PVC-U and PE. The use of polypropylene and a special wall design makes the system easy to install; it has a high mechanical strength, is characterised by a high chemical and heat resistance, and its operational life is estimated at a minimum of 100 years. Very good material properties attained by polypropylene polymerisation mean that products made of PP are very popular on the market, and their market share is growing rapidly with reference to the traditional solutions of PVC-U, stoneware or concrete.

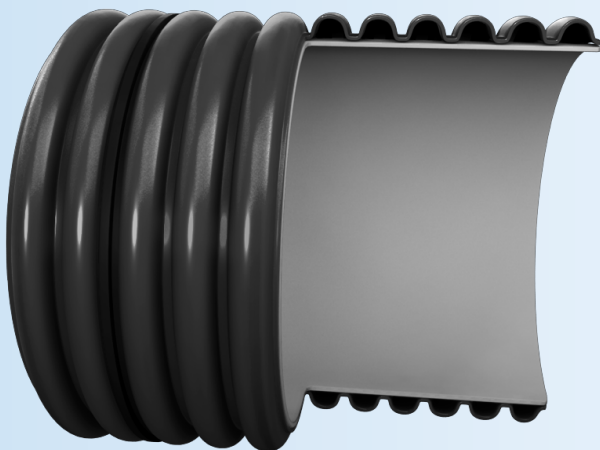

**The MAGNACOR system** is manufactured in diameters from 200 to 600 mm and its very good properties result from the use of a block polypropylene to obtain a copolymer as the raw material. The pipes of this system are produced using the extrusion method. A pipe wall is constructed of two layers: an inner layer – smooth, and an outer layer – corrugated. Both layers are connected with one another molecularly in the extrusion process, forming a uniform, solid structure. The double wall design provides excellent protection. This solution allows attaining a low weight of the pipes. Their installation is therefore much easier than other sewerage systems. A smooth inner surface creates minimum pipe resistance for flowing waste waters while keeping even extremely small slopes of sewers, eliminates depositing sediments and thus prevents sludge putrefaction or the formation of congestions. It reduces both labour and financial outlays on cleaning of sewage networks during their many years' operation.

## ADVANTAGES OF THE SYSTEM

- High class of ring stiffness SN8 kN/m<sup>2</sup>, heavy-duty type pipe
- Low weight of pipes – PP pipes are more than two times lighter than PVC-U pipes, lower transport costs and much easier assembly in trenches
- Chemical resistance to waste waters within the range of pH 2 to 12 (in accordance with the ISO/TR10358 report), as well as against salt and means for road maintenance in winter
- Thermal resistance to waste water of a temperature up to 95°C – for continuous flow, up to 130°C – for short-term flow
- High mechanical resistance at negative temperatures (even down to -20 degrees C), allowing conducting assembly work under harsh winter conditions
- High compression strength and impact resistance thanks to the pipe design and high quality of raw material
- Simple installation – a system with pipes with sockets, pipes without sockets, with the necessary range of fittings: sleeves, bends, tees and reducers
- Easy to install in a concrete well – special wall sleeves to paste in well walls
- Easy to connect to the existing public sewers with smooth walls
- Able to be cut into pieces of any length, and very simple ways to connect, without any specialistic tools thanks to the applied seal and a wide range of fittings
- Active adaptation to surrounding ground conditions thanks to corrugated profile of pipe
- Resistance to chemical, biological and stress corrosion
- High longitudinal stiffness of pipe, easy for maintaining a constant slope in a trench
- Very good resistance to abrasion in accordance with PN-EN 13476

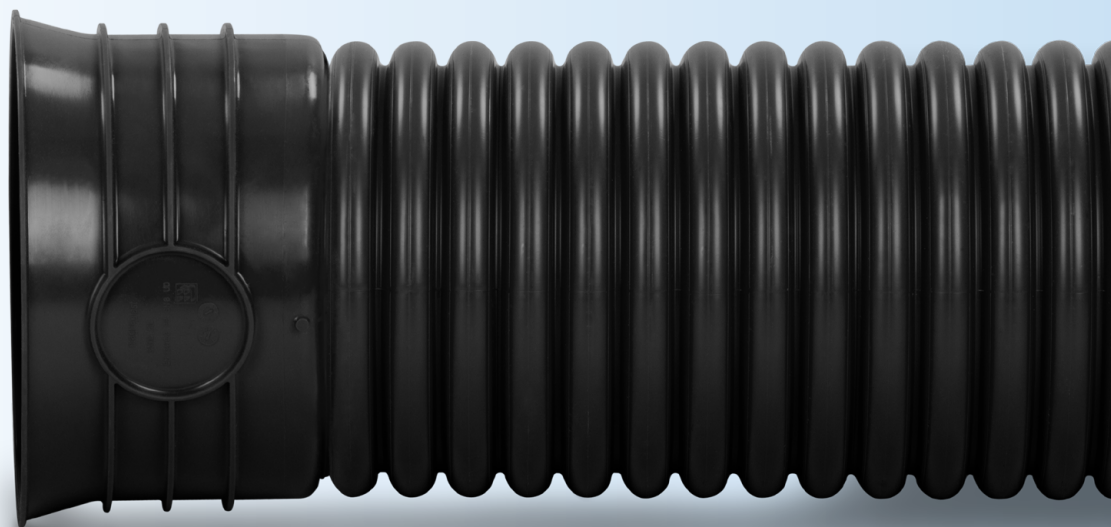

## USE

**MAGNACOR sewage system** is used to build non-pressure sewage systems, rainwater systems, combined sewer systems, and drainage systems. It is used to discharge sanitary and municipal wastewaters and effluents from: car parking lots, roads, highways, airports and landfills. Due to its properties, polypropylene enables installing the MAGNACOR system in sewers with high temperature effluents, directly behind decompression wells owing to its high resistance to low  $\text{pH} \geq 2$  (a high concentration of hydrogen sulphide in the wastewater), to discharge industrial wastewater, and as a road culvert.



The pipes are manufactured in ring stiffness class SN8 (8kN/m<sup>2</sup>), in lengths: 3 and 6 metres. Pipe fittings produced with injection moulding method as well as heat sealing and extrusion welding, are equipped with a wall of a ribbed structure and a smooth pipe socket. MAGNACOR pipes and fittings are produced in black or in an optional red-brown colour outside and light grey inside. A smooth inner surface in a light grey colour provides very good visibility while surveying the pipelines by means of a TV camera.

## DESIGN

Hydraulic calculations of pipeline's cross-sections and profiles consist in determining pipeline dimensions, levels of filling with wastewater and flow rates. Calculations are carried out on the basis of a design flow rate and a predesigned pipeline slope as well as an absolute roughness of pipeline walls on the assumption that:

- the dimension, shape of the pipeline, its slope, roughness and the assigned design flow does not change throughout the whole designed length of pipeline;
- in all points of the pipeline's cross-section, there are the same values of flow velocities.

To find the pipe diameter, TABLE 1 can be used, that presents the maximum flow capacity of MAGNACOR sewage pipes for domestic sewage systems for the minimum slope (at  $v = 0.8\text{m/s}$ ) and the maximum (at  $v = 3\text{m/s}$ ).

Diameter	Minimum slopes sanitary sewage system	Maximum waste water flow dm <sup>3</sup> /s	Maximum slopes for effluent flow 3m/s	Maximum waste water flow dm <sup>3</sup> /s
200 mm	4,0 ‰	26	54 ‰	99
250 mm	3,1 ‰	39	41 ‰	145
300 mm	2,4 ‰	56	33 ‰	210
400 mm	1,6 ‰	105	22 ‰	390
500 mm	1,3 ‰	160	17 ‰	590
600 mm	1,0 ‰	225	13 ‰	850

*Table 1 Flow capacity of MAGNACOR pipes against pipeline slope*

For rainwater drainage the flow capacity will be higher as the maximum waste water speed may then be up to 5 m/s.

In the case of planning a sewage system made of MAGNACOR pipes, with the necessity to apply minimum slopes, you can use the values shown in Table 2.

Diameter	Minimum slopes for sanitary and industrial sewage system, $v = 0.8\text{ m/s}$	Minimum slopes for rainwater drainage $v=0.7\text{ m/}$
200 mm	4,0 ‰	3,0 ‰
250 mm	3,1 ‰	2,4 ‰
300 mm	2,4 ‰	2,0 ‰
400 mm	1,6 ‰	1,3 ‰
500 mm	1,3 ‰	0,9 ‰
600 mm	1,0 ‰	0,8 ‰

*Table 2 Permissible minimum slopes for the individual diameters of MAGNACOR pipes*



Due to the complex character of the formula for hydraulic calculation of gravity pipelines for MAGNACOR pipes, below you can find Nomogram 1 for hydraulic calculation of completely filled double-walled pipes for an assumed roughness factor  $k = 0.40\text{mm}$  (for sewers with side inlets and sewer manholes), and Nomogram 2 of efficiency curves for circular cross-section.

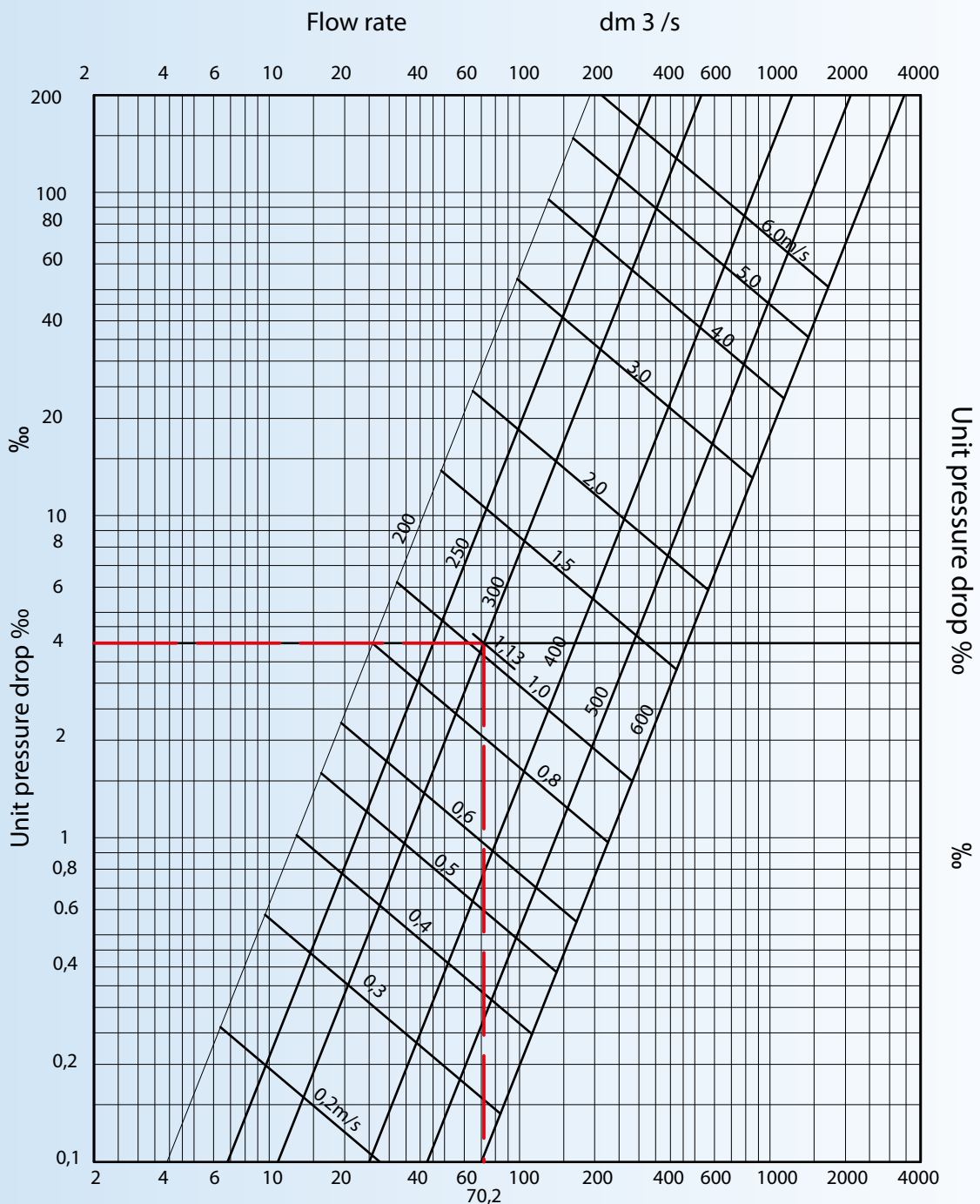

Nomogram 1 for hydraulic calculation of completely filled double-walled pipe for temperature  $10^\circ\text{C}$  and roughness  $0.40\text{ mm}$



**EXAMPLE**
Data:

- The actual flow rate  $Q_{rz} = 48 \text{ m}^3/\text{s}$
- Assumed slope of sewer  $4\text{‰}$
- Assumed diameter 300 mm

To calculate:

- waste water flow speed
- waste water filling level in pipeline

Solution: From the Nomogram for  $k = 0.4$  with the completely filled sewer cross-section for  $i = 4\text{‰}$  and for the scope of minimum speed  $0.8 \text{ m/s}$ , we receive a pipe of diameter = 300 mm. For pipe dia. 300 mm and slope  $4\text{‰}$ , from the Nomogram for  $k = 0.40 \text{ mm}$ , we read out flow rate and speed with a completely filled pipe cross-section:

$$Q_c = 70,2 \text{ dm}^3/\text{s}, \quad V_c = 1,03 \text{ m/s}$$

We determine the coefficient  $a = Q_{rz} / Q_c = 48/70.2 = 0.68$

From Nomogram 2 of efficiency curves for round pipelines, for  $\alpha$ , we read out respectively acc. to the arrows:

a)  $h/d_{\text{inner}} = 0,604$ , since  $d_{\text{inner}} = 300\text{mm}$  then filling level  $h = 181 \text{ mm}$

b)  $\beta = V_{\text{actual}} / V_{\text{total filling}} = 1,08$ , przy  $V_{\text{total filling}} = 1,03 \text{ m/s}$  to  $V_{\text{actual}} = 1,1 \text{ m/s}$

The result: we reaffirm the chosen pipe diameter 300 mm with the sewer slope  $i = 4\text{‰}$  and flow rate  $48 \text{ dm}^3/\text{s}$  —> waste water speed will be  $1 \text{ m/s}$  and filling level  $h = 181 \text{ mm}$ , i.e. 70% of the complete sewer pipeline filling level.

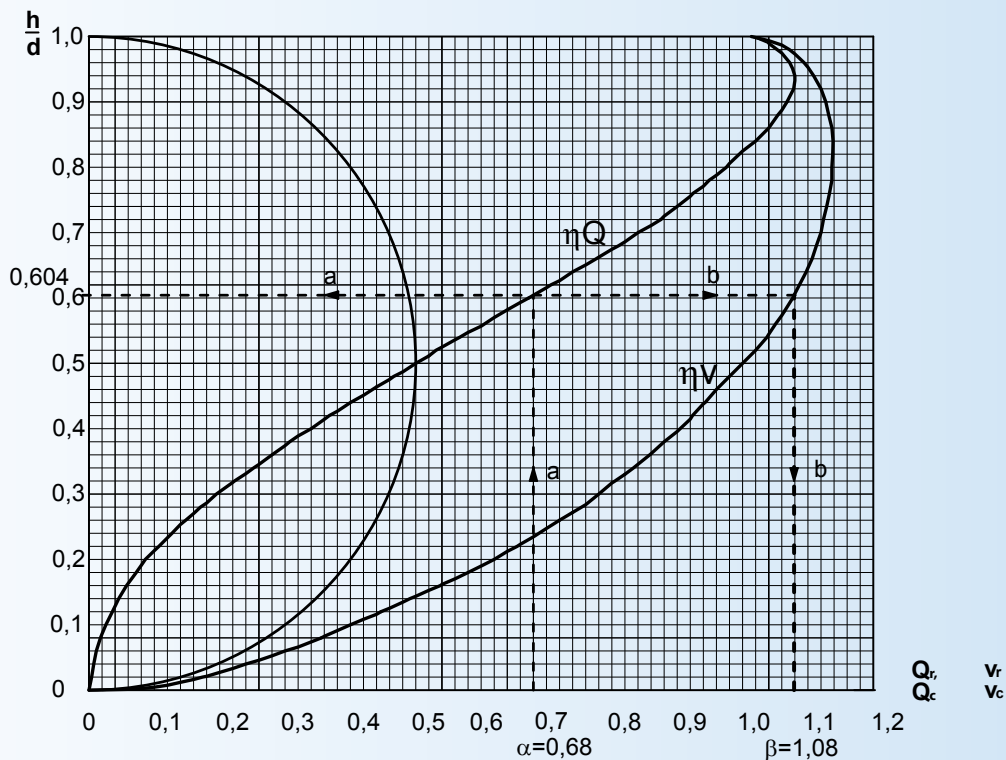

*Nomogram 2 of efficiency curves for circular cross-section.*

## STORAGE



Pipe diameter	Number of pipes per pallet
200	20
250	12
300	9
400	4
500	2
600	2

**MAGNACOR pipes** should be stored in a horizontal position on an even ground level, with no stones or sharp objects, preferably in their original manufacturer’s packaging. Special attention should be paid to the fact that while arranging pallets in a pile, the protective boards are not to be laid directly on the pipe, but on the board of the pallet laid below. When the pipes are stored loose they should be laid on the ground with wooden beams under, spaced with one another at a max. distance of 2.0 metres. The number of pipes in a pile will be dependent on their diameter. Pipes and fittings of the MAGNACOR system can be stored outdoors; however, the period of storage should not exceed 1 year. Stored in such conditions, the products should be secured against the harmful effects of precipitation and solar radiation that cause pipe discolouration. Tests revealed that even several years of UV radiation exposure does not have any negative impact on pipe functional characteristics and life expectancy; however, for reasons of appearance it is recommended to protect them. For this purpose, tarpaulins or a black film may be used. When accepting pipes at the construction site, they have to be visually checked if they are not damaged.

## ASSEMBLY

Connecting pipes of the **MAGNACOR system** is done by means of pipe sockets made on pipes or by means of fittings. To seal pipe connections, it is necessary to apply an elastomeric seal that is mounted in the penultimate notch of the pipe, after thorough cleaning any impurities from inside the pipe socket and on seal.



To get a good connection, the seal should be coated with a lubricant. Pipes can be cut into smaller sections using a manual or a mechanical saw directly on the construction site. The cutting is made in a pipe groove at a right angle to its axis and then the cutting surface is thoroughly cleaned of cutting chips and burrs. It is estimated that installation of pipelines in the MAGNACOR system allows a minimum of 20% savings in time compared with any other types of pipes. The pipes should be laid in a trench, with their sockets put in the opposite direction to the wastewater flow. The MAGNACOR system can be freely coupled by means of appropriate fittings with the smooth piping system of the external sewage network (KG system), and with the system of sewage chambers (SC), offered by company MAGNAPLAST. After the assembly completion of the sewage network, it is necessary to perform a leakage test in accordance with PN-EN 1610.

## PIPE LAYING CONDITIONS

To take full advantage of all benefits of MAGNACOR pipes it requires providing suitable conditions for their laying, backfilling, soil compaction and meeting the requirements of the standard **PN-ENV 1046: 2007**. General guidelines in this respect:

1. 1. In every situation it is necessary to make the trench bottom even, to clean it of stones, dewater and to make a sand bed, if required, (the height of sand bedding depends on soil type):

- a) No bedding layer – natural soil (consistent with design requirements), grain-size up to  $\varnothing 40$  mm – lay out the pipes on trench bottom after preparing pipeline bearing;
- b) 10cm thick bedding layer, grain-size up to  $\varnothing 22$  mm for pipes, DN = 200, for dry soil and with grain-size up to  $\varnothing 40$  mm for pipes DN >200 and up to DN < 600;
- c) 15 cm, grain-size as above, for watered soil – the earth work should be carried out only in a dewatered trench;
- d) 25 cm in rocky soils or with grain-size greater than  $\varnothing 40$  mm.

Make the bedding of bulk soil, one- or multi-fraction material: coarse sand with a small content of fine particles, sand-gravel mix or crushed-stone aggregate of particle size from 2 mm to 40 mm. Compact the bedding layer exactly – minimum 0.85 of Proctor scale.

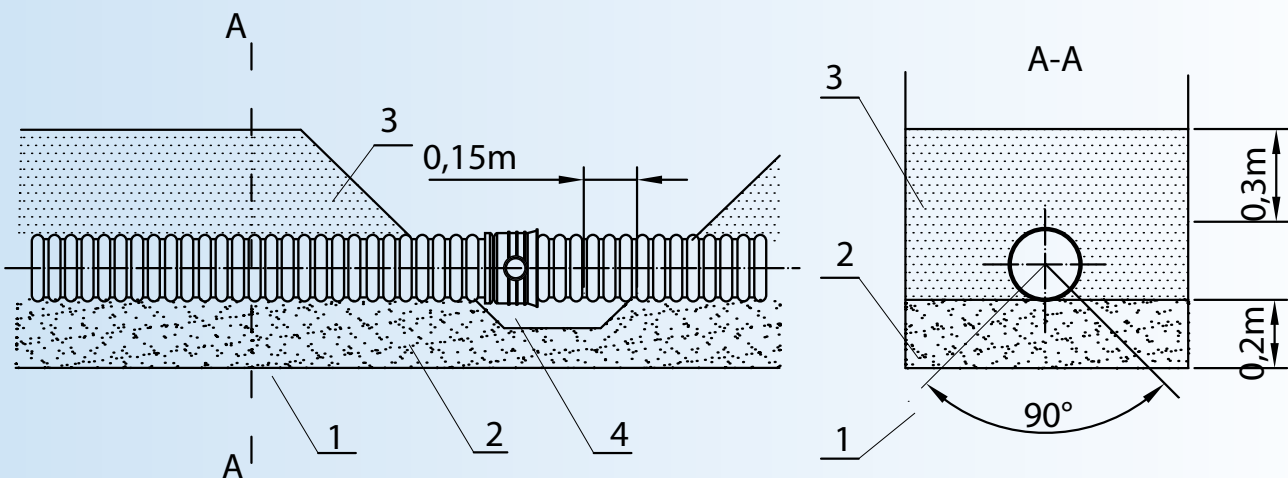

2. Making backfill:

a) Haunching:

- Make haunching with the material used for bedding, dropping it symmetrically with layers from 15 to 20 cm thick, compacting the soil thoroughly with light equipment (up to the height of 1.0 m above the pipeline) in a way that it does not cause excessive dynamic loads, and does not allow displacing the pipe;
- Use the light equipment,



**b) Backfilling the trench:**

- Material for backfilling does not require to be accurately selected as haunching; however, it is necessary to remove all stones of a considerable size, organic materials, tree roots, trash etc., out of the pipe trench.
- Make the backfilling using mechanical equipment, with soil compaction with layers, considering local requirements such as a location within a zone of road and the necessity for soil compaction to achieve a Procter value of 0.95 min.;
- The backfilling in green areas should be carried out with the use of natural soil, without the need to achieve the compaction value required in other cases, such as for roads.

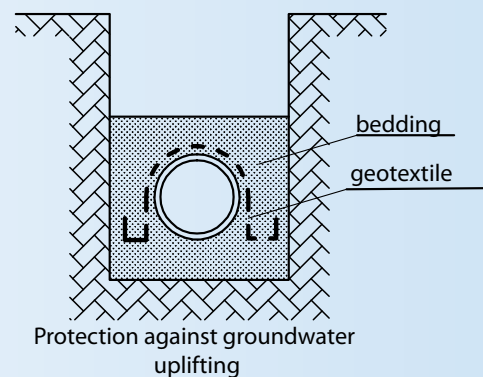
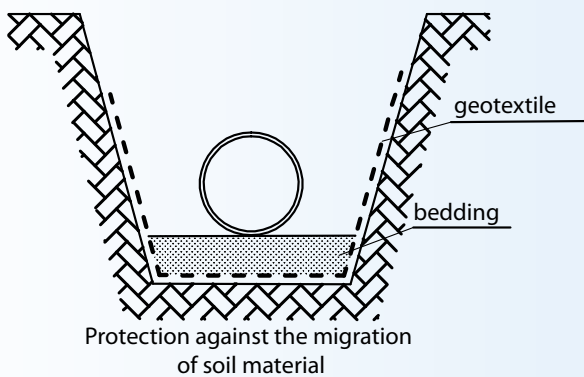
**SPECIAL PIPE LAYING CONDITIONS**
**1. Pipe protection against the particle migration of soil material and against uplifting caused by groundwater elevation;**

**2. Laying pipes in a freezing zone:**

- Limitations of MAGNACOR pipe location in a freezing zone in an area without road traffic loads arise from the need to apply adequate thermal insulation. Insulating material can be: expanded polystyrene (EPS) or light weight concrete aggregate (LECA).
- In the case of areas loaded with road traffic, the minimum backfilling of MAGNACOR pipes acc. to PN-EMI 1046:2007 is 1.0 m, recommended by TEPPFA – 0.8 m, and 0.5 m in accordance with the Nordic method (Molina). However, it is necessary to take into account the issue of thermal insulation and its compression strength. A simple solution is to use a bulk material that is easily compacted, which is LECA or blast-furnace slag.

**3. High groundwater level**

- Laying MAGNACOR pipes requires trench dewatering. Trench dewatering is done by: water removal from trench while deepening it, by means of pumps located at the top of the excavation, with a method of horizontal drainage (consisting in laying out a horizontal drainage system with water discharge to intake wells, situated along the trench), a method of depression (consisting in lowering the static groundwater level using depression wells or wellpoints).

# CERTIFICATES

MAGNACOR was released for sale and for common use in the construction industry on the basis of the following standards and approvals:

- Declaration of Conformity acc. to Polish Standard PN-EN 13476-3 No. 041
- Technical Approval IBDiM No. AT/2013-02-2959
- Technical Approval IBDiM No. AT/07-2012-0249
- Insta-Cert certificate for non-pressure underground drainage and sewerage: EN 13476 – Nordic Poly Mark

INSTITUT BADAWCY DRÓG I MOSTÓW  
03-302 Warszawa, ul. Instytutowa 1  
tel. sekretariat: 22 814 50 25, fax: 22 814 50 28

Warszawa, 10 maja 2013 r.

**APROBATA TECHNICZNA IBDiM  
Nr AT/2013-02-2959**

Na podstawie § 16 pkt 2 rozporządzenia Ministra Infrastruktury z dnia 8 listopada 2004 r. w sprawie aprobat technicznych oraz jednostek organizacyjnych upoważnionych do ich wydawania (Dz. U. Nr 249, poz. 2497 ze zm.), po przeprowadzeniu postępowania specjalnego, którego wnioskodawcą jest producent o nazwie:

**MAGNAPLAST Sp. z o.o.**  
z siedzibą: Sieniawa Żarska 69, 68-213 Lipinki Łużyckie

Instytut Badawczy Dróg i Mostów  
świadczą pozytywną ocenę techniczną i przydatność wyrobu budowlanego:

**Rury i kształtki z polipropylenu (PP), z polietylenu (PE) do przepustów drogowych oraz do osłony przewodów i kabli**  
o nazwie handlowej: **Rury i kształtki MAGNACOR**

do stosowania w budownictwie – w instalacji komunikacyjnej – w zakresie stosowania i przeznaczenia oraz przy spełnieniu warunków podanych w niniejszej Aprobacie Technicznej IBDiM.

Instytut Badawczy Dróg i Mostów dla wyżej wymienionego wyrobu budowlanego wskazuje obowiązujący system 4 oceny zgodności.

 **DYREKTOR**  
prof. dr hab. inż. Leszek Rafalski

Data wydania Aprobaty Technicznej: 10 maja 2013 r.  
Data utrzymania ważności Aprobaty Technicznej: 10 maja 2018 r.

Dokument Aprobaty Technicznej IBDiM Nr AT/2013-02-2959 zawiera stron 15 w tym załącznik.

**Główny Instytut Górnictwa  
JEDNOSTKA CERTYFIKUJĄCA**  
Pl. Gwarków 1  
40 - 166 KATOWICE

**CERTYFIKAT ZGODNOŚCI  
Nr CZ/1966/II/2012**

WYDANY ZGODNIE Z SYSTEMEM CERTYFIKACJI WYROBÓW NA PODSTAWIE PROGRAMU PCW-ISO/IEC 5

NAZWA I ADRES POSIADAJĄCA CERTYFIKATU: **"MAGNAPLAST" Sp. z o.o., 68-213 LIPINKI ŁUŻYCKIE, Sieniawa Żarska 69.**

NAZWA I ADRES PRODUCENTA: **"MAGNAPLAST" Sp. z o.o., 68-213 LIPINKI ŁUŻYCKIE, Sieniawa Żarska 69.**

NAZWA WYROBU: **Rury i kształtki Magnacor z polipropylenu (PP) do podziemnego bezciśnieniowego odwadniania i kanalizacji**

TYP (ODMIANY): **Typ „B”**

KOD ICS: 23.040.01; 93.030

ZASTOSOWANIE: Do odprowadzania nieczystości i ścieków bytowo-gospodarczych (także o wysokiej temperaturze), przemysłowych oraz do odwadniania dróg i autostrad.  
Symbol obszaru zastosowania „UD”

PODSTAWOWE PARAMETRY DEKLAROWANE PRZEZ PRODUCENTA: Rury i kształtki o średnicy nominalnej DN 200 + 600 mm!  
Pozostałe parametry wg dokumentacji wymienionej na stronie 2 certyfikatu

WYRÓB SPŁYNIA WYMAGANIA ZAWARTÉ W: Normie PN-EN 13476-3 + A1: 2009 - „Systemy przewodów rurowych z tworzyw sztucznych do podziemnego bezciśnieniowego odwadniania i kanalizacji. Systemy przewodów rurowych o ściankach strukturalnych i nieplastyfikowanego poli(chloru winitu) (PCV-U), polipropylenu (PP) i polietylenu (PE). Część 3: Specyfikacja rur i kształtek o gładkiej powierzchni wewnętrznej i profilowanej powierzchni zewnętrznej oraz systemu, typ B”

ZGODNIE Z DOKUMENTACJĄ I SPRAWODZANIAM Z BADAŃ: **Wg wykazu na stronie 2 certyfikatu**

Prawo do posługiwania tym certyfikatem w okresie od 20 kwietnia 2012r. do 29 kwietnia 2015r., dotyczy wyłącznie szeregów wyrobów posiadających identyczne właściwości (parametry), jak przedstawiono do badań wzór (wzory) i odpowiadających wymaganiom określonym powyżej.



Niniejszy certyfikat nie obejmuje wymagań innych – poza wyżej wymienionymi – przepisów prawnych i norm mających dotyczyć tego wyrobu

Z-ca Kierownika GIG-IC: **N I E R O W I N I K.**  
Zastępca Kierownika Wydziału: **mgr inż. Jędrzej Drabik**

 **Główny Instytut Górnictwa  
JEDNOSTKA CERTYFIKACJI**  
dr inż. Dariusz Świątek

Katowice, dnia 29 kwietnia 2012 r. Strona 1/2

Główny Instytut Górnictwa, Jednostka Certyfikacji, 40-166 Katowice, Plac Gwarków 1, tel. 32 259-23-61, fax: 32 259-23-69

**magnoplast**  

**Deklaracja zgodności nr 041**

- Producent wyrobu budowlanego:**  
MAGNAPLAST Sp. z o.o., Sieniawa Żarska 69, 68-213 Lipinki Łużyckie  
*(nazwa, adres i adres siedziby przedsiębiorstwa)*
- Nazwa wyrobu budowlanego:**  
Rury kanalizacyjne MAGNACOR o ściankach strukturalnych (szwastawstwach) z polipropylenu (PP) lub polietylenu (PE) oraz kształtki od DN100 do DN1600 Klasa SM4 - SM8  
*(nazwa, nazwa handlowa, typ, oznaczenie, materiał, kolor)*
- Klasyfikacja strukturalna wyrobu budowlanego:**  
PP/PE (PP lub PE) **22.21.21.0; 22.21.21.29.0**  
*(kod ICS)*
- Przeznaczenie i zakres stosowania wyrobu:**  
Rury i kształtki strukturalne MAGNACOR przeznaczone są do systemów kanalizacji grawitacyjnej (sanitarnej, deszczowej) poprzez ułożenie w gruncie w pasie drogowym (pod jezdnią) i poza jezdnią lub na innych terenach wykorzystywanych do celów inżynierskich komunikacyjnych. Mogą być również stosowane do wykonania przepustów i osłon przez nisy drogowie oraz do osłony przewodów kabli  
*(ogólnie z przewodem osłoniętym)*
- Specyfikacja techniczna:**  
POLSKA NORMA PN-EN 13476-3 + A1:2009  
Systemy przewodów rurowych z tworzyw sztucznych do bezciśnieniowego podziemnego odwadniania i kanalizacji (sanitarnej, deszczowej) oraz do osłony przewodów i kabli w systemach strukturalnych z nieplastyfikowanego poli(chloru winitu) (PCV-U), polipropylenu (PP) i polietylenu (PE).  
Część 3: Specyfikacja odwozu rur i kształtek z gładką powierzchnią i profilowaną powierzchnią zewnętrzną i profilowaną powierzchnią wewnętrzną oraz systemu, typu B.  
Aprobata Techniczna IBDiM Nr AT/2013-02-2959 z dnia 10.05.2013  
Rury i kształtki z polipropylenu (PP), z polietylenu (PE) do przepustów drogowych oraz do osłony przewodów i kabli.  
Aprobata Techniczna IK AT/07-2012-0249-20  
Rury kanalizacyjne MAGNACOR o ściankach strukturalnych (szwastawstwach) i kształtkach fabrycznych (jednowarstwowych) z polipropylenu (PP) lub polietylenu (PE) wysokiej gęstości  
*(nazwa, adres i adres siedziby producenta wyrobu budowlanego)*
- Deklarowane cechy techniczne typu wyrobu budowlanego:**  
Sztywność obwodowa [kNm<sup>2</sup>]: Klasa SM4 – SM8  
system oceny zgodności – 4  
*(inne właściwości mechaniczne i wytrzymałościowe)*
- Nazwa i numer akredytowanej jednostki certyfikującej lub laboratorium oraz certyfikatu lub numeru raportu z badań typu, jeżeli taka jednostka brała udział w zastosowaniu systemu oceny zgodności wyrobu budowlanego:**  
NIE DOTYCZY

Deklaruję z pełną odpowiedzialnością, że wyrobem budowlanym jest zgodny ze specyfikacją techniczną wskazaną w pkt 5.

Sieniawa Żarska 18.06.2013

 **magnoplast** Sp. z o.o.  
Sieniawa Żarska 69, 68-213 Lipinki Łużyckie  
NIP 828-10-00-828

 **Główny Instytut Górnictwa  
JEDNOSTKA CERTYFIKACJI**  
Pl. Gwarków 1, 40-166 Katowice  
NIP 780-00-00-000

**INSTA-CERT**  
Insta B 0

**LICENCE OF CERTIFICATION**

Date of valid edition: 2012-08-27 No: 5119  
Date of issue: 2012-08-27 Reference:

Licensee's name and address: Conformity mark covered by license  
Magnoplast Sp. z o.o.  
Sieniawa Żarska 69  
PL-68-213 Lipinki Łużyckie  
Poland

Information regarding licensee/manufacturer

Licensee's technical officer: Telephone: +48 68 363 2711, Fax: +48 68 363 2772  
E-mail: Daniel.buczynski@magnoplast.com.pl  
Manufacturer: Magnoplast Sp. z o.o., Sieniawa Żarska 69, Lipinki Łużyckie

Product covered by the license

Type of product	Standard normative document	Specific rules
Plastics pipes and fittings for non-pressure underground drainage and sewerage – Structure wall piping systems of unplasticized poly(vinyl chloride) (PVC-U), polypropylene (PP) and polyethylene (PE).	EN 13476:2007	INSTA SBC EN 13476

Specification of product  
MAGNACOR PP pipes, DN100, 200 and 300 mm with socket, SM4, size group 1 and 2, buried in ground either the building structure and outside the building (application area code "UD").  
MAGNACOR PP pipes, DN100, 500 and 600 mm with socket, SM4, size group 2 and 3, buried in ground outside the building structure (application area code "LF").

Additional information according to the enclosure.

The licensee above is hereby given permission to use the INSTA-CERT mark on or in connection with products, which fulfil the requirements of the standard or the normative document covered by the licence issued by the licensee above. INSTA-CERT mark will also be valid for marks defined in enclosure IPE. The certificate/ licence is valid on condition that the licensee complies with the "General rules for certification by members of INSTA-CERT" and the specific rules applying to certification of products of the type mentioned. The licensee is obliged to inform INSTA-CERT in writing of any claim for damages or any other expenses to which persons may become liable as a result of injuries caused by a product manufactured or sold by the licensee. This also applies to defective or faulty products.

The licence is valid for one calendar year, unless the licensee or member of INSTA-CERT gives at least three months notice to the company. The licence will be re-issued with an amended "date of valid edition" if the content and/or conditions of the licence have been changed.

The licence is not transferable.

**MEMBER OF INSTA-CERT**  
SP Jędrzej Drabik  
Insta B 0

INSTA-CERT LICENCE

## LIST OF VALID STANDARDS

to design and construct sewerage networks and laterals

- 1) **PN-EN 752:2000** Drain and sewer systems outside buildings  
**PN-EN 752-1:** General terms and definitions  
**PN-EN 752-2:** Requirements  
**PN-EN 752-3:** Planning  
**PN-EN 752-4:** Hydraulic design and environmental considerations
- 2) **PN-EN 476:2001** General requirements for components used in drains and sewers
- 3) **PN-EN 1610:2002** Construction and testing of drains and sewers
- 4) **PN-ENV1046: 2007** Plastics piping systems. System outside building structures to transfer water or waste water. Practice to install under the ground and above the ground
- 5) **PN-EN 1917:2004** Concrete manholes and inspection chambers, unreinforced, steel fibre and reinforced
- 6) **PN-EN 13598-1:2011** Plastics piping systems for non-pressure underground drainage and sewerage. Unplasticized poly(vinyl chloride) (PVC-U), polypropylene (PP) and polyethylene (PE). Part 1. Specifications for ancillary fittings including shallow inspection chambers.
- 7) **PN-EN 13598-2:2009** Plastic piping systems for non-pressure underground drainage and sewerage. Unplasticized poly(vinyl chloride) (PVC-U), polypropylene (PP) and polyethylene (PE) Part 2. Specifications for manholes and inspection chambers in traffic areas and deep underground installations.
- 8) **PN-EN 13598-2: 2009/AC:2009** Plastic piping systems for non-pressure underground drainage and sewerage. Unplasticized poly(vinyl chloride) (PVC-U), polypropylene (PP) and polyethylene (PE) Part 2. Specifications for manholes and inspection chambers in traffic areas and deep underground installations.
- 9) **PN-EN 124:** Gully tops and manhole tops for vehicular and pedestrian areas.
- 10) **PN-EN 13476-3+A1:2009** Plastic piping systems for non-pressure underground drainage and sewerage. Structured-wall piping systems of unplasticized poly(vinyl chloride) (PVC-U), polypropylene (PP) and polyethylene (PE) – Part 3: Specifications for pipes and fittings with smooth internal and profiled external surface and the Type B system.

December 2013

## Pipes with socket class C - SN8 without gasket MCEM

DN / ID [mm]	d1 [mm]	d2 [mm]	D [mm]	L [mm]	L1 [mm]	Art. No.
200	197	226	259	3000	152	83028
200	197	226	259	6000	152	83045
250	249	284	320	3000	181	84028
250	249	284	320	6000	181	84045
300	297	339	386	3000	218	85028
300	297	339	386	6000	218	85045
400	396	453	506	3000	223	86028
400	396	453	506	6000	223	86045
500	500	573	635	3000	264	87028
500	500	573	635	6000	264	87045
600	598	683	765	3000	329	88028
600	598	683	765	6000	329	88045

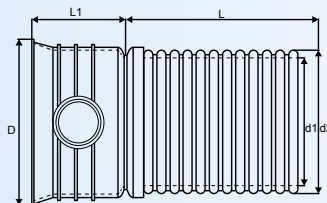

## Pipes without socket class C - SN8 MCEL

DN / ID [mm]	d1 [mm]	d2 [mm]	L [mm]	Art. No.
200	197	226	6000	83090
250	249	284	6000	84090
300	297	339	6000	85090
400	396	453	6000	86090
500	500	573	6000	87090
600	598	683	6000	88090

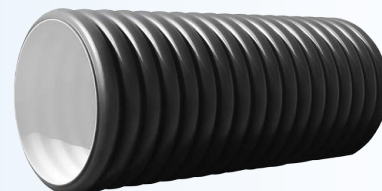
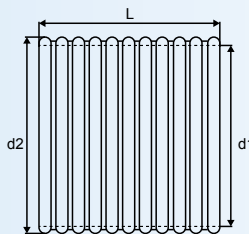

## Pipe connectors MCMM

DN / ID [mm]	D [mm]	d2 [mm]	L [mm]	Art. No.
200	259	226	304	83200
250	320	284	358	84200
300	386	339	434	85200
400	506	453	444	86200
500	635	573	528	87200
600	765	683	658	88200

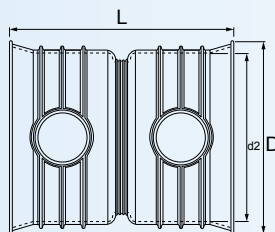



## Sleeves MCU

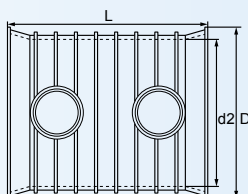

DN / ID [mm]	D [mm]	d2 [mm]	L [mm]	Art. No.
200	259	226	306	83180
250	320	284	360	84180
300	386	339	438	85180
400	506	453	448	86180
500	635	573	500	87180
600	765	683	620	88180

## Wall sleeves MCF

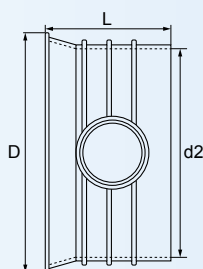

DN / ID [mm]	D [mm]	d2 [mm]	L [mm]	Art. No.
200	259	226	153	83620
250	320	284	180	84620
300	386	339	219	85620
400	506	453	224	86620
500	635	573	250	87620
600	765	683	310	88620

## Reducers MCR

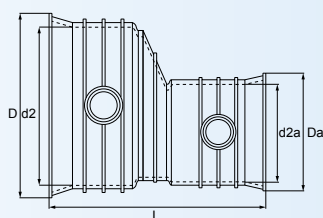

DN1/ DN2 [mm]	D [mm]	d2 [mm]	L [mm]	Da [mm]	d2a [mm]	Art. No.
250/200	320	284	359	259	226	84280
300/250	386	339	425	320	284	85280
400/300	506	453	498	386	339	86280
500/400	635	573	531	506	453	87280
600/500	765	683	635	635	573	88280

## End caps MCK

DN / ID [mm]	D [mm]	d2 [mm]	L1 [mm]	L [mm]	Art. No.
200	259	226	162	83240	83240
250	320	284	189	84240	84240
300	386	339	227	85240	85240
400	506	453	232	86240	86240
500	635	573	274	87240	87240
600	765	683	339	88240	88240

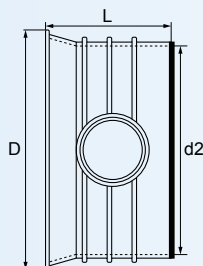

## Plugs MCM

DN / ID [mm]	d2 [mm]	L [mm]	Art. No.
200	226	155	83220
250	284	180	84220
300	339	218	85220
400	453	220	86220
500	573	260	87220
600	683	320	88220

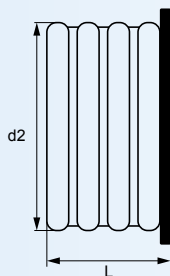

## Connectors for KG pipe (socket) MC-KGI

DN / ID [mm]	d [mm]	d2 [mm]	L [mm]	Art. No.
200	200	226	253	83230
250	250	284	306	84230
300	315	339	346	85230
400	400	453	376	86230
500	500	573	440	87230

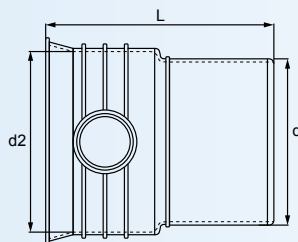

## Bends MCB

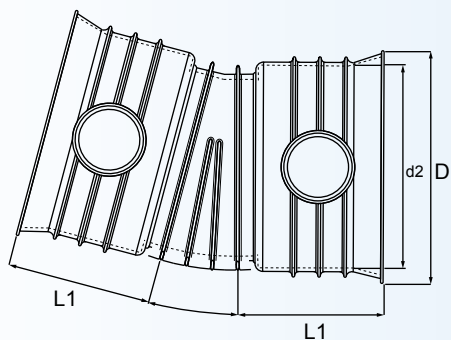

DN / ID [mm]	D [mm]	d2 [mm]	$\alpha$	L1 [mm]	Art. No.
200	259	226	15°	163	83100
250	320	284	15°	195	84100
300	386	339	15°	231	85100
400	506	453	15°	253	86100
200	259	226	30°	163	83110
250	320	284	30°	195	84110
300	386	339	30°	231	85110
400	506	453	30°	253	86110
200	259	226	45°	163	83120
250	320	284	45°	195	84120
300	386	339	45°	231	85120
400	506	453	45°	253	86120
200	259	226	90°	163	83130
250	320	284	90°	195	84130
300	386	339	90°	231	85130
400	506	453	90°	253	86130

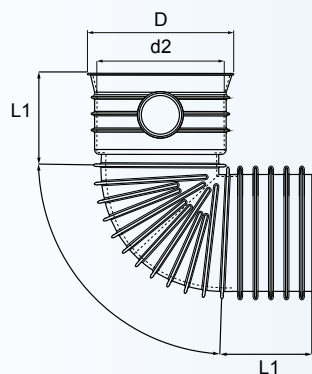

DN / ID [mm]	D [mm]	d2 [mm]	$\alpha$	L1 [mm]	Art. No.
500	635	573	15°	279	87100
600	765	683	15°	362	86100
500	635	573	30°	279	87110
600	765	683	30°	362	88110
500	635	573	45°	279	87120
600	765	683	45°	362	88120
500	635	573	90°	279	87130
600	765	683	90°	362	88130

## Tees for Magnacor 45° MCEA

DN1/DN2 [mm]	D [mm]	d2 [mm]	M [mm]	Da [mm]	d2a [mm]	L [mm]	Art. No.
MCEA 200/200	259	226	395	259	226	630	81330
MCEA 250/200	320	284	410	259	226	770	82330
MCEA 250/250	320	284	480	320	284	770	82340

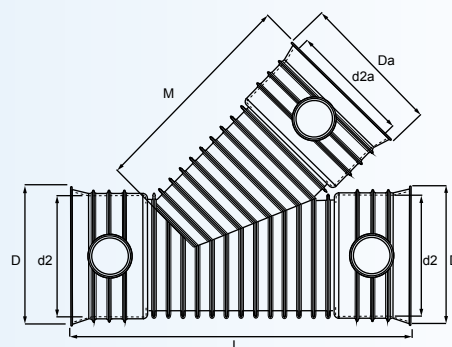

## Tees for Magnacor 45° MCEA

DN1/DN2 [mm]	D [mm]	d2 [mm]	M [mm]	Da [mm]	d2a [mm]	L [mm]	Art. No.
MCEA 300/200	386	339	450	259	226	860	83330
MCEA 300/250	386	339	530	320	284	910	83340
MCEA 300/300	386	339	650	386	339	1050	83350
MCEA 400/200	506	453	450	259	226	850	84330
MCEA 400/250	506	453	530	320	284	910	84340
MCEA 400/300	506	453	615	386	339	1030	84350
MCEA 400/400	506	453	730	506	453	1270	84360
MCEA 500/200	635	573	450	259	226	950	85330
MCEA 500/300	635	573	615	386	339	1090	85350
MCEA 600/200	765	683	450	259	226	1100	86330
MCEA 600/300	765	683	615	386	339	1280	86350

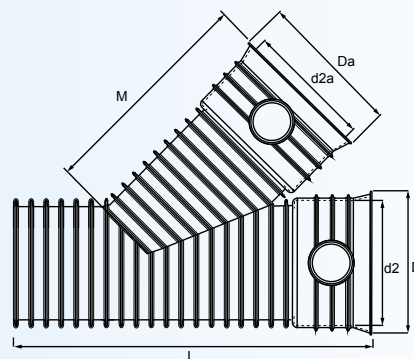



## Tees for KG 45° MCEA-KG

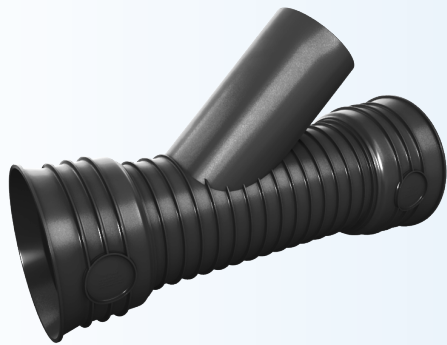

DN1/DN2 [mm]	D [mm]	d2 [mm]	M [mm]	d [mm]	L [mm]	Art. No.
MCEA-KG 200/200	259	226	345	200	630	81335
MCEA-KG 250/200	320	284	410	200	770	82335
MCEA-KG 250/250	320	284	425	250	770	82345

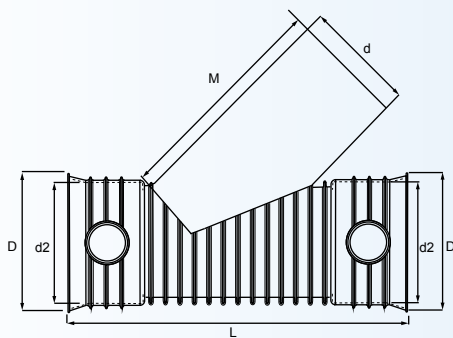

## Tees for KG 45° MCEA-KG

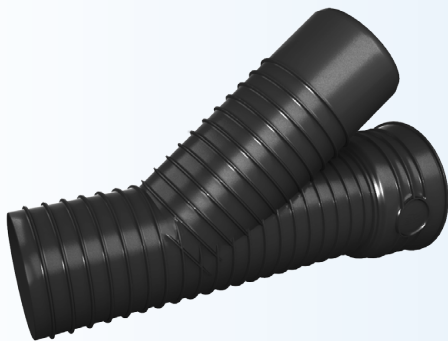

DN1/DN2 [mm]	D [mm]	d2 [mm]	M [mm]	d [mm]	L [mm]	Art. No.
MCEA-KG 250/160	320	284	330	160	700	82325
MCEA-KG 300/160	386	339	330	160	780	83325
MCEA-KG 300/200	386	339	380	200	860	83335
MCEA-KG 300/250	386	339	450	250	910	83345
MCEA-KG 400/200	506	453	380	200	850	84335
MCEA-KG 400/250	506	453	450	250	910	84345
MCEA-KG 500/200	635	573	380	200	950	85335
MCEA-KG 600/200	765	683	380	200	1100	86335
MCEA-KG 600/250	765	683	450	250	1190	86345

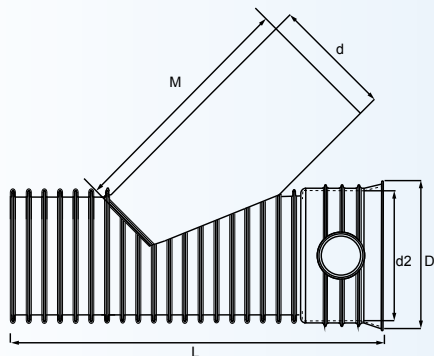

## Tees for Magnacor 90° MCEA

DN1/DN2 [mm]	D [mm]	d2 [mm]	M [mm]	Da [mm]	d2a [mm]	L [mm]	Art. No.
MCEA 200/200	259	226	215	259	226	600	81331
MCEA 250/250	320	284	250	320	284	770	82341
MCEA 250/200	320	284	220	259	226	630	82331
MCEA 300/200	386	339	220	259	226	700	83331
MCEA 300/250	386	339	250	320	284	740	83341
MCEA 300/300	386	339	300	386	339	870	83351
MCEA 400/200	506	453	220	259	226	745	84331
MCEA 400/250	506	453	250	320	284	800	84341
MCEA 400/300	506	453	290	386	339	860	84351
MCEA 400/400	506	453	330	506	453	970	84361
MCEA 500/200	635	573	220	259	226	810	85331
MCEA 500/300	635	573	290	386	339	950	86351
MCEA 600/200	765	683	220	259	226	935	86331
MCEA 600/300	765	683	290	386	339	1110	86351

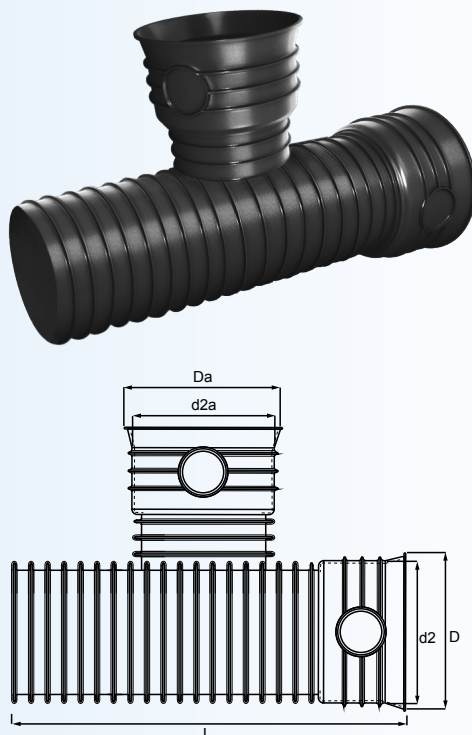

## Tees for KG 90° MCEA-KG

DN1/DN2 [mm]	D [mm]	d2 [mm]	M [mm]	d [mm]	L [mm]	Art. No.
MCEA-KG 200/200	259	226	180	200	620	81336
MCEA-KG 250/250	320	284	200	250	700	82346
MCEA-KG 250/200	320	284	180	200	630	82336
MCEA-KG 300/200	386	339	180	200	700	83336
MCEA-KG 300/250	386	339	200	250	740	83346
MCEA-KG 400/200	506	453	180	200	745	84336
MCEA-KG 400/250	506	453	200	250	800	84346
MCEA-KG 500/200	635	573	180	200	810	85336
MCEA-KG 600/200	765	683	180	200	935	86336
MCEA-KG 600/250	765	683	200	250	1020	86346

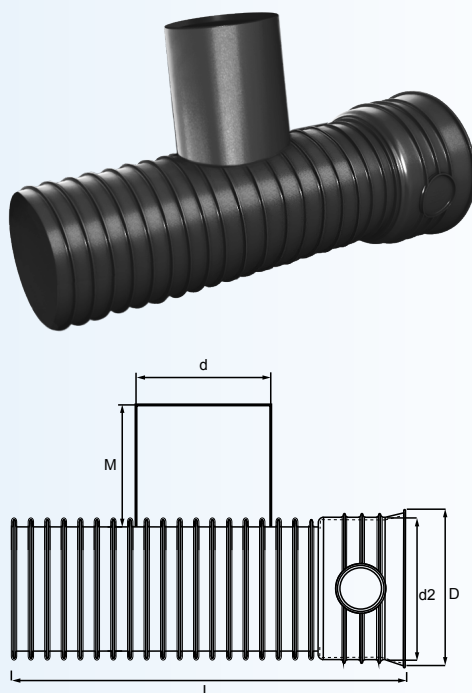

## Gaskets for pipes MC



DN / ID [mm]	Art. No.
200	7235
250	7245
300	7255
400	7265
500	7275
600	7285

## Gaskets “in situ”



DN / ID [mm]	Art. No.
110	34615
160	34320
200	34325



Inside sewage PP HTplus



Noiseless inside sewage PP Skolan-dB



Outside sewage PVC KG

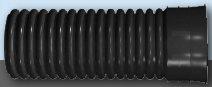

Outside sewage PP Magnacor

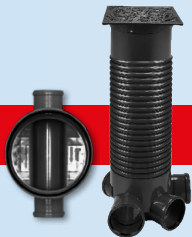

Sewage chambers SC



Polyethylene pipes PE



Drainage pipes DR

Official Distributor:

**MAGNAPLAST SP. Z O.O. SIENIAWA ŻARSKA 69, 68-213 LIPINKI ŁUŻYCKIE, POLAND**

TEL.: (+48 68) 363 27 00, FAX.: (+48 68) 363 27 72,

Internet: [www.magnoplast.com.pl](http://www.magnoplast.com.pl), e-mail: [magnoplast@magnoplast.com.pl](mailto:magnoplast@magnoplast.com.pl)

We leave ourselves right to change construction and technical features of our products